

VBM DOMOBAR INSTRUCTION MANUAL



Available languages



Table of Contents

[Table of Contents](#)

[DESCRIPTION DES SYMBOLES](#)

[UTILISATION PRÉVUE](#)

[MAUVAISE UTILISATION](#)

[DESCRIPTION DE LA MACHINE](#)

[DONNÉES TECHNIQUES](#)

[SÉCURITÉ](#)



VBM

As once and never before.

VBM DOMOBAR
—
DOMOBAR
DIGITAL

Manuale di Istruzioni *Istruzioni originali*

Instruction manual *Translation of original instructions*

Manuel d'Instructions *Traduction des instructions d'origine*

Bedienungsanleitung *Übersetzung der Originalanleitung*

Manual de instrucciones *Traducción de las instrucciones originales*

ITA

ENG

FRA

DEU

ESP

ITA

VIBIEMME SRL

via Charles Gounod, 25/27 -
 20092 Cinisello Balsamo, Milan, Italy
 T. (+39) 02 660 16691 · F. (+39) 02 660 16636
 info@vbmespresso.com · www.vbmespresso.com



ENG

DOMOBAR,

FRA

Timbro rappresentante locale*Stamp of local agent**Timbre du représentant local**Stempel des lokalen Vertreters**Sello representante local***Modello n°***Model**Modèle**Modell**Modelo*

DEU

Revisione n°*Rev. No.**Rév. N.**Überarbeitung**Rev. N.*

0

Data*Date**Date**Datum**Fecha*

06-2020

Note*Remarks**Notas**Notiz**Notas*

Emissione documento - Document issued - Emission document
 Ausgangsbeleg - Emisión documento

Revisione documento - Document review - Document
 d'examen - Prüfung der Unterlagen - Revisión de documentos

Revisione documento - Document review - Document
 d'examen - Prüfung der Unterlagen - Revisión de documentos

ESP



INSTRUCTION MANUAL, INDEX.



-
- 1 GENERAL INFORMATION**
 - 1.1 DESCRIPTION OF SYMBOLS
 - 1.2 INTENDED USE
 - 1.3 IMPROPER USE
-
- 2 CHARACTERISTICS**
 - 2.1 DESCRIPTION OF THE MACHINE
 - 2.2 TECHNICAL DATA
 - 2.3 SAFETY
-
- 3 UNPACKING AND POSITIONING**
 - 3.1 UNPACKING THE MACHINE
 - 3.2 EQUIPMENT
 - 3.3 WINGS ASSEMBLY
 - 3.4 POSITIONING THE MACHINE
-
- 4 COMPONENT IDENTIFICATION**
-
- 5 CONNECTIONS**
 - 5.1 WATER SUPPLY
 - 5.2 ELECTRICAL CONNECTION

6 DESCRIPTION OF BUTTONS AND LIGHTS

7 OPERATION

- 7.1 WATER TRANSPORTATION
- 7.2 FIRST START
- 7.3 START
- 7.4 PREPARING COFFEE
- 7.5 HOT WATER SUPPLY
- 7.6 DISPENSING STEAM

8 CLEANING

- 8.1 CLEANING GENERAL INFORMATION
- 8.2 DAILY CLEANING
- 8.3 CONTROLS AND REPLACEMENTS

9 GUIDE TO THE SOLUTION OF SOME PROBLEMS

10 DISPOSAL

11 ELECTRICAL SCHEME



1, GENERAL INFORMATION.

Vibiemme S.r.l. has taken every possible precaution to ensure safe operation and efficient equipments. The safety devices built in are designed to protect operators and authorized technicians.

- Please read this manual before installing, starting and using the machine. Failure to do so may result in equipment damage, poor machine performance, health hazards, or personal injury.
- This manual is an integral part of the machine and must be available to the user and / or maintenance performer. In case of loss or request for more information, contact your local dealer or the manufacturer. The manual reflects the state of technology at the present time and can not be considered inadequate for any subsequent updates: the manufacturer reserves the right to modify the manual without the obligation to update previous versions, except in exceptional cases.
- The device can be used by children aged not under 14 years and persons with reduced physical, sensory or mental capabilities, or lack of experience or the necessary knowledge, provided under surveillance or after that they have received instructions to ensure safe operation and to the understanding of the dangers inherent in it. Children should not play with the appliance. Cleaning and maintenance meant to be performed by the user does not have to be made by children without supervision.

IT IS FORBIDDEN:

- Operate the machine without observing safety rules in force in the country of installation;
- operate the machine in the absence of connection of grounding. Failure to do so may result in electric shock;
- replace or remove the safety decals and nameplate affixed directly on the machine and on the packaging, for installation and use proper and safe;
- touch groups or nozzles during operation of the machine. The lances must be handled only by the grips. The beverages dispensed and some parts of the machine are hot and can cause burns;
- remove or tamper with any part of the machinery and NOT make unauthorized modifications. Contact authorized and specialized technical in the area;
- pull the power cord to disconnect the plug;
- let the machine to be used by children or unsuitable staff;
- expose the machine to the weathering (sun, rain etc ...);
- leave the machine in places where the ambient temperature is at or below 0°C, as the residue of water in the boiler could freeze and cause damage;
- install the machine in places where are used water jets that could reach the machine;
- operate the machine if any door or panel is not properly closed;
- insert spoons, forks or other utensils into the inner parts of the machine;
- operate the machine in the absence of water;
- fill the tank with hot or boiling water;
- obstruct ventilation openings: Leave at least 10 cm. of space between the machine and any walls, and at least 5 cm on both sides, to allow proper ventilation.

**FOR CORRECT OPERATION, USE:**

- Only ground coffee.
- Only fresh network water , suitably softened (~ 7 French degrees).
- Only original spare parts Vibiemme S.r.l.

FAILURE TO COMPLY WITH THESE INSTRUCTIONS EXCLUDES THE POSSIBILITY OF BENEFIT OF THE GUARANTEE AND THE MANUFACTURER OR MAINTENANCE TECHNICIAN DECLINES ANY LIABILITY.

VIBIEMME S.R.L.DISCLAIMS ANY RESPONSIBILITY IN THE FOLLOWING CASES:

- If the machine is used in different ways than those described in this manual;
- if you do not conform to the requirements of safety and maintenance;
- if you do not use original spare parts Vibiemme;
- if **INSTALLER** or **MAINTENANCE TECHNICIAN**, is not authorized and specialized;
- **THE INSTALLER** or **MAINTENANCE TECHNICIAN** must inform the manufacturer of **POSSIBLE MALFUNCTION** or misuse that could affect the safety of the original system.
- **CHECK** conditions of the components and, if defective, stop the installation and ask for their replacement.
- **If the machine is to remain unused for a long time you need to disconnect the power and water supply if connected.**



1.1, DESCRIPTION OF SYMBOLS.

Information regarding the operations at risk in this manual are marked with the following symbols which indicate:



Danger due to **electricity**.



ATTENTION!

General danger or miscellaneous information.



Thermal hazard (burns).



WARNING

Danger to machine damage.



1.2,

INTENDED USE.

The coffee machine has been created and designed solely for dispensing espresso coffee and for the preparation of hot drinks (The, cappuccino, etc) by means of hot water or steam supply.

Only for this application it is to be used, any other use is considered improper and therefore dangerous.

1.3,

IMPROPER USE.

The coffee machine was built and designed for a food use only and so it is forbidden to:

- introduce liquids other than water;
- heat drinks or other non-food substances;
- introduce, in the filter holder, other than ground coffee;
- place on the holding surface other objects other than cups and mugs;
- place containers with liquids on the holding surface;
- block the air vents with cloth or other materials;
- cover the holding surface with a cloth;
- touch the dispensing area with the hands;
- use the machine if it is heavily wet.

IMPORTANT

IN THIS SECTION WE HAVE LISTED SOME SITUATIONS OF REASONABLY FORESEEABLE MISUSE. HOWEVER, THE USE OF THE MACHINE MUST COMPLY WITH THE INFORMATION IN THE SECTION "INTENDED USE".

2.1, DESCRIPTION OF THE MACHINE.

The following are the main features of the semi-automatic espresso machine with lever controlled dispensing.

- Copper boiler in reservoir for the production of hot water and steam.
- Boiler load by vibration pump activated by coffee dispensing lever.
- Pre-calibrated thermostat for control of the correct pressure in the boiler.
- The heating element is constituted by an electrical resistor immersed in the boiler; it allows the heating of the water and the steam production.
- Dispensing unit in chrome-plated brass.
- Vibration pump.
- Water / steam nozzle in chrome- copper plated with ergonomic knob.
- Water tanks in plastic for food use having a capacity of 1.8 lt.
- Control of water level of the reservoir through the sensor.
- Display and LED keys for coffee delivery, steam delivery, hot water delivery and alarm signalling.

2.2, TECHNICAL DATA.

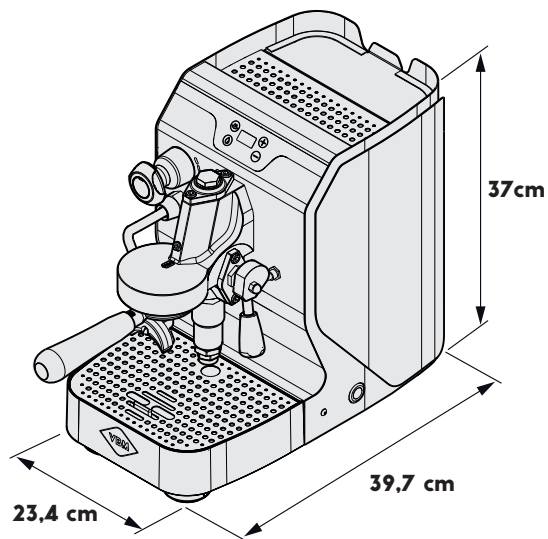

ENG

Boiler capacity	0,5 liters	
Electrical connection	230 V/50/1 - 7,4 A	115 V/60/1 - 14,8 A
Power	1400 W	
Noise	< 70 db	

Temperature of operation	+5° to +30°C
---------------------------------	--------------

Storage temperature	+5° to +40°C
----------------------------	--------------

Net weight	15 kg
-------------------	-------

2.3, SAFETY.

- Panels of protection of the inner parts fastened with screws.
- Water level sensor.

When the water reaches the minimum level (1,5 cm from the bottom) automatically all the functions of the machine are disabled, the keys go off and the flashing alarm symbol appears on the display.

Turn off the machine by placing the main switch on "OFF" and fill the water tank as described in the relevant paragraph.

SAFETY THERMOSTAT

- It turns on when the temperature in the boiler reaches 150°C by disconnecting the voltage to the resistance in order to prevent the burn.



3, UNPACKING AND POSITIONING.

3.1, UNPACKING THE MACHINE.

- Always check the integrity of the packaging: inform the carrier of any damage.
- Cut the straps (1) and open the upper part (2) of the package.
- Take out the accessories: equipment and technical documentation (manuals).
Open the cellophane and lift the machine by FROM BASE.
- The elements (cardboard, cellophane, metal staples etc.) Can cut or injure if not handled carefully or if used incorrectly; keep away from the reach of the children or unauthorized people.

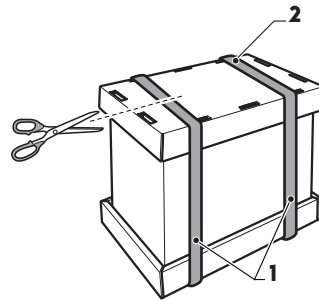

3.2, EQUIPMENT.

- 1 2 coffee filter holder.
- 2 1 coffee filter holder.
- 3 Measure.
- 4 Presser.
- 5 Blind filter.
- 6 Brush.
- 7 Instruction manual.
- 8 Wings.

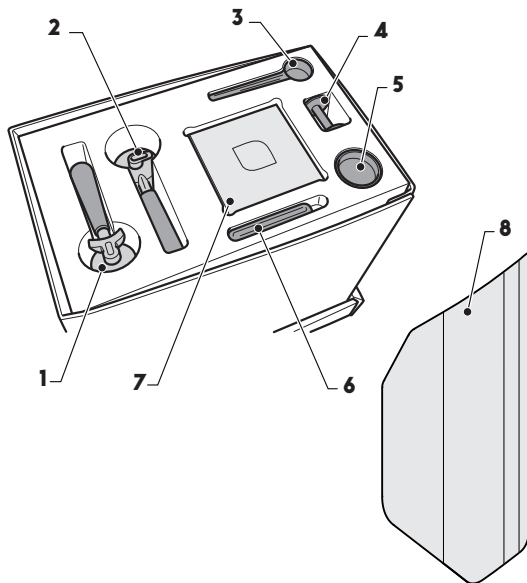

3.3,

WINGS ASSEMBLY.

Assemble the wings (1) supplied by hooking the buttons on the wings with the relative matching points (2) on the machine body.

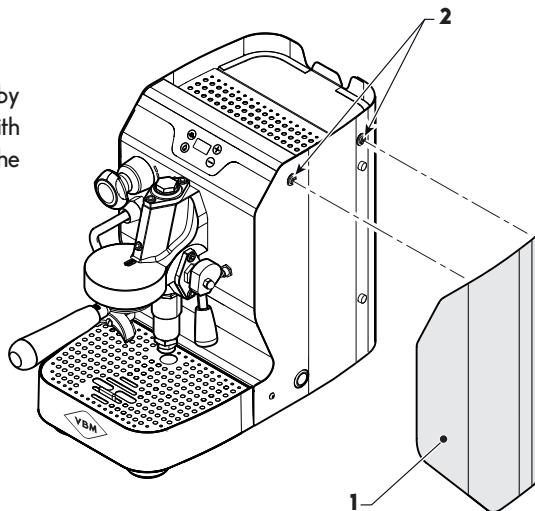

ENG

3.4,

POSITIONING THE MACHINE.

Place the machine in its final location, making sure that:

- the movable support is sufficiently strong and stable, taking into account the weight of the machine, and that is not tilted;
- there are at least 10 cm. between the wall and rear and side walls of the machine and any walls, to allow proper ventilation;
- the upper floor of the machine (holding surface) should not exceed 150 cm from the floor.

4, COMPONENT IDENTIFICATION.

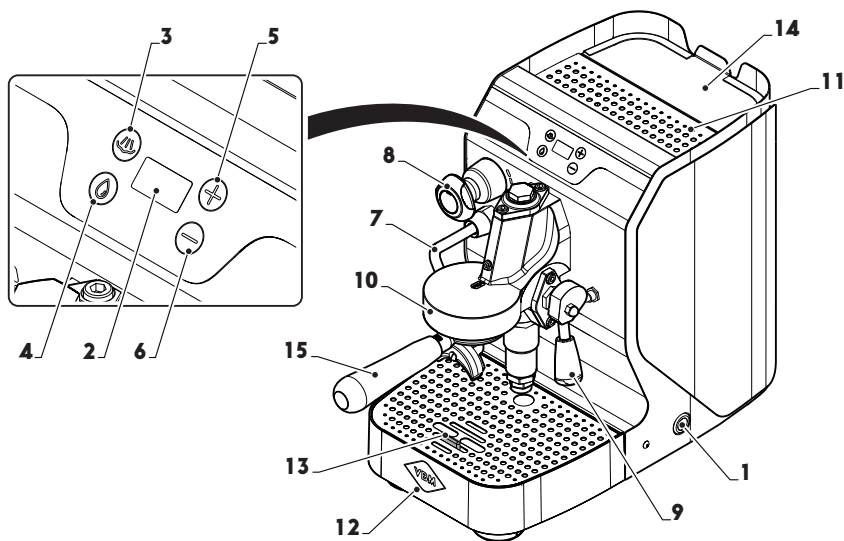

- | | | | |
|---|--|----|------------------------------|
| 1 | Luminous main switch "ON/OFF". | 8 | Steam supply control handle. |
| 2 | Display. | 9 | Coffee dispensing lever. |
| 3 | Steam "ON/OFF" led key. | 10 | Coffee dispensing group. |
| 4 | Hot water "ON/OFF" led key. | 11 | Shelf holding surface. |
| 5 | Led key for coffee temperature increase. | 12 | Removable drip tray. |
| 6 | Led key for coffee temperature decrease. | 13 | Bowl liquid level float. |
| 7 | Spear steam / hot water. | 14 | Water tank cover. |
| | | 15 | Filter holder. |



5, CONNECTIONS.

5.1, WATER SUPPLY.

This model does not require connection to the water supply, the water for brewing coffee, suitably softened, it is taken from the rear tank.

ENG

5.2, ELECTRICAL CONNECTION.

The machine is connected to the mains with the power cord of equipment, with plug.



Check that all switches are in the "OFF" position.

- It is absolutely mandatory connection of grounding, and the correspondence of the system with applicable regulations in the country of installation.
- Check the power supply (see data plate); It must match the local power supply.
- You may not use extension cords and jumper cables; the workplace is inevitably exposed to water and humidity that affect the conditions of isolation system.
- **If the power cord is damaged**, it must be replaced with one having the same characteristics, only by the installer / maintainer authorized and specialized. Failure to do so may cause damage and result in electric shock.

6,

DESCRIPTION OF BUTTONS AND LIGHTS.

MAIN SWITCH ON/OFF (1):

- The machine is equipped with a power switch with two positions:

OFF position: no power to internal components of the switch line LED off.

ON position: power supply for electrical operating components. The switch LED lights up.

DISPLAY (2):

- By turning the main switch to the ON position, the display lights up, it indicates: the selected function (coffee delivery - steam delivery - hot water delivery), the temperature and time of coffee delivery, alarm codes.

STEAM "ON/OFF" LED KEY (3):

- Once pressed, the key lights up and the steam symbol appears on the display (2) indicating the activation of the steam production function via the lance (6). To exit the steam supply phase, press the key again.

HOT WATER "ON/OFF" LED KEY (4):

- Once pressed, the key lights up and the hot water symbol appears on the display (2) indicating the insertion of the pump for the delivery of hot water via the lance (6). To exit the hot water supply phase, press the key again.

LED KEYS FOR COFFEE TEMPERATURE INCREASE/DECREASE (5):

- Once pressed, they increase/decrease the temperature of the brewed coffee. When the temperature is changed this will remain stored for the next delivery until a new variation.

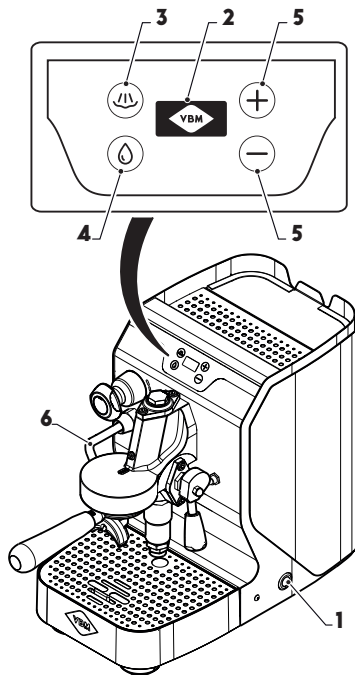



7, OPERATION.

7.1, WATER SUPPLY.

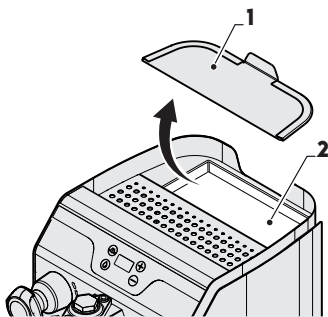

- Lift the cover (1), remove and fill the tank (2) with softened cold water (1,8 litres) (or natural mineral water).
- Replace the cover (1).



The lack of water in the tank (the minimum level) inhibits the functioning of the resistance and the water supply to the coffee.

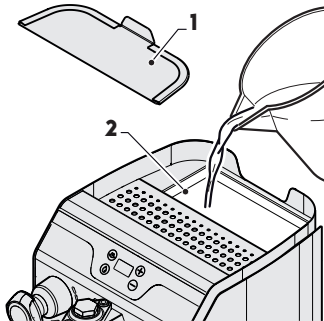

7.2,

FIRST START.

- Load water as described in paragraph "Water load".
- Press the line switch (1) which lights up and the water heating is activated, the logo (A) appears on the display.
- Wait for the boiler water temperature to be reached, indicated by the appearance of screen (B) on the display.
- Lift the lever (2) and hold it up until of the group (3) comes water, indicating that the boiler is full of water, and then lower the lever (2).
- Turn off the machine by pressing the main switch (1) again.

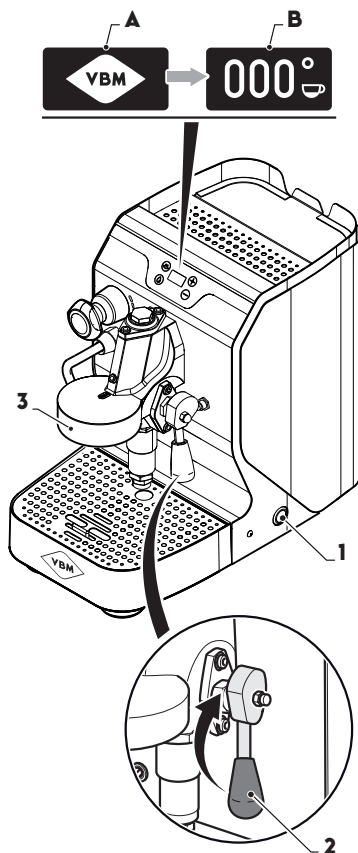

7.3,

START.

- Press the line switch (1) which lights up and the water heating is activated, the logo (A) appears on the display.
- Wait for the boiler water temperature to be reached, indicated by the appearance of screen (B) on the display at this point the machine is ready to be used.

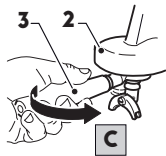
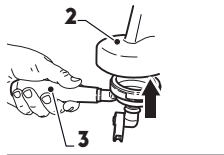
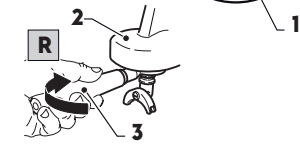
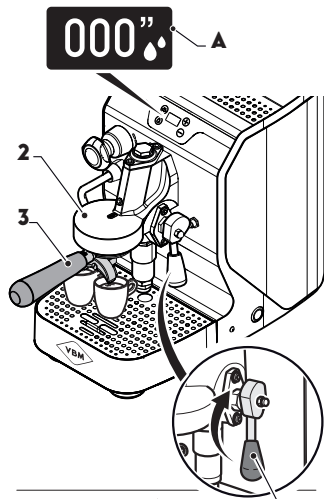

7.4, PREPARING COFFEE.

- With filter holder mounted lift the lever (1) and make a dispensing so as to bring the temperature in the group (2), and then lower the lever (1).
- Remove the filter holder (3) from the group (2) by turning it as indicated by the arrow "R".
- Discard any funds present.
- Fill the filter with the dose of coffee (one coffee a single dose, two doses for two cups of coffee).
- Clean the edge of the filter to eliminate traces of coffee and be sure there is perfect seal between the filter and the group.
- Fit the filter holder (3) on the group (2) lifting it so as to insert the tabs into the seat of the group (2) and turn the filter holder (3) to switch in the direction of the arrow "C".
- Place one or two hot cups under the filter holder according to the type of filter holder used.
- Lift the lever (1) to brew the coffee, screen (A) appears on the display indicating the brewing time; once the desired quantity is reached, lower the lever (1) to stop dispensing.
- It is recommended to remove the filter holder from the machine to perform a short dispensing to clean the shower and then reassembling the filter holder.



NOTE: Immediately make coffee dispensing once the filter holder IS in the group; leaving the coffee in the filter holder without making an immediate dispensing will result in burnout of the coffee powder and the brewed coffee is bitter.



ATTENTION: Be careful not to touch the group (2) danger of scalding.

- If desired, the coffee temperature can be changed before brewing.
- To increase or decrease the temperature, use the keys (4) and (5).
- The value shown on screen (B) flashes until the new set point is reached, at this point it is possible to brew the coffee.



NOTE: If the temperature is changed this will remain stored for the next delivery until a new variation.

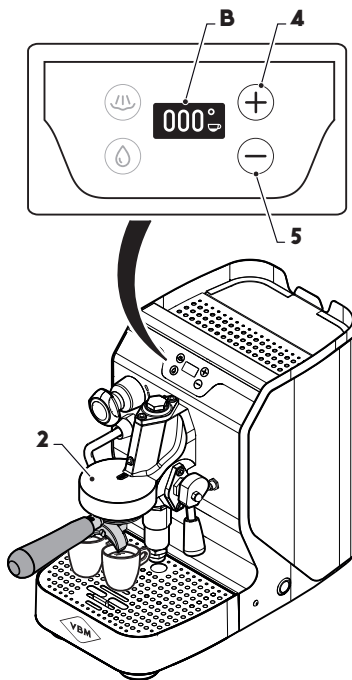



7.5,

HOT WATER SUPPLY.

- Press the key (1) which lights up, the water pump starts.
- The hot water icon (A) appears on the display which flashes during the heating phase, once the temperature is reached the hot water icon remains fixed.
- Remove the lance (2) from the machine.



ATTENTION: The lance (2) is very hot. Move the lance only with proper rubber protection; Danger of scalding.

- Place a cup under the lance (2).
- Open the tap slowly turning the knob (3) counterclockwise.
- Once you reach the desired amount, close the tap (3).
- To exit the water supply function, press the key (1) again which goes off.



ATTENTION: Do not leave for a long time the key (1) on, the water pump continues to operate by pumping water in the boiler. Leave inserted the key (1) the time required for the hot water supply.

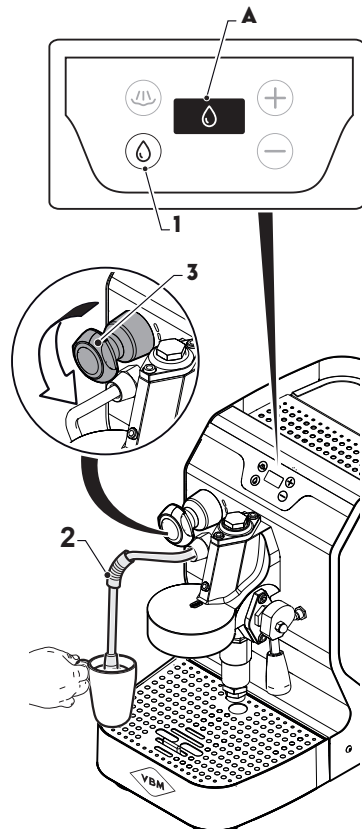

7.6,

STEAM DISPENSING.

- Press the key (1) which lights up, the resistance for overheating of the water contained in the boiler is automatically activated.
- The steam icon (A) appears on the display which flashes during the heating phase, once the temperature is reached the steam icon remains fixed.
- To exit the steam supply function, press the key (1) again which goes off.



ATTENTION: immediately after reaching the set steam temperature indicated by the fixed illumination of the symbol (A), the key (1) must be positioned on "OFF" to avoid burning the resistance.

- Turn the steam lance (2) to the bowl and then make a short supply dispense of steam by slowly turning the knob (3) counterclockwise to remove any residual water present in the circuit.



ATTENTION: The lance (2) is very hot. Move the lance only with proper rubber protection; Danger of scalding.

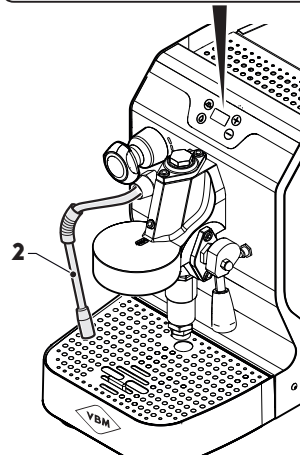
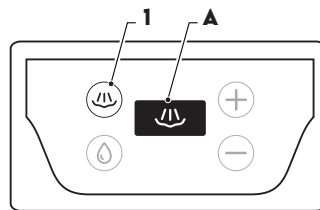

- Remove the steam lance (2) to the outside then put a cup or a pot full of liquid to be heated under the lance (2).
- Fully immerse the nozzle of the steam lance into the liquid and slowly open the valve (3) by turning it counterclockwise.
- Once reached the desired temperature close the tap (3).
- Turn the steam lance (2) to the bowl and then make a short dispensing to clean the inside of the jet and clean the nozzle (2) with a damp cloth to prevent the fouling difficult to remove.



Raise the lever (4) and perform dispensing of water by the group to fill the boiler water and eliminate the steam present.

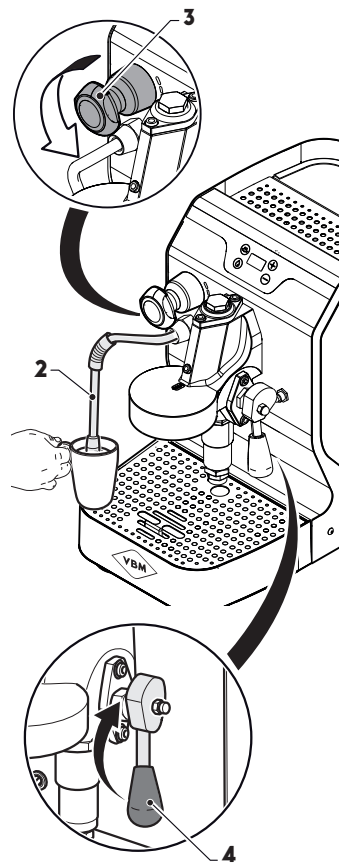

8.1.

ALARMS.

STEAM TIME OUT ALARM

- After starting the resistance and reaching the water overheating temperature, deliver the steam within 120 seconds.
- Once the time out time has elapsed, the resistance indicated by the buzzer is deactivated, the error code (**E01**) appears on the display and the key (1) lights up red.
- Remove the alarm by pressing the key (1), the only operation that can be performed.

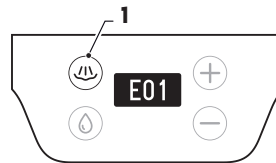

HOT WATER TIME OUT ALARM

- After starting the pump and reaching the water heating temperature, deliver the hot water within 120 seconds.
- After the time out time, the pump is deactivated, indicated by the buzzer, the error code (**E02**) appears on the display and the key (2) lights up red.
- Remove the alarm by pressing the key (3), the only operation that can be performed.

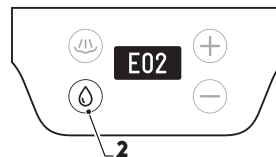

PROBE MALFUNCTION ALARM

- In case of probe malfunction, the code (**E03**) appears on the display.
- It will no longer be possible to carry out any operation and the keys are disabled, turn off the machine and contact the Service Centre.



8.

ALARMS AND SETTINGS.

EMPTY TANK ALARM

- When the water level in the tank drops below the minimum level, the symbol (3) empty tank appears on the display.
- When the alarm symbol appears, all the keys will be deactivated until the tank is filled as described in paragraph "7.1".

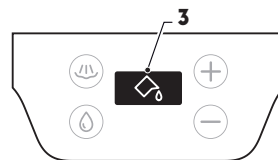

8.2,

EXTRA SETTING.

- This setting allows you to change the temperature unit of measurement (°C or °F), the machine is set by default with the celsius unit of measurement (°C)
- To change the unit of measurement, press and hold down the key (A) for 5 seconds until the keys (A) and (B) turn yellow.
- At this point, change the unit of measurement by pressing the keys (A) and (B).
- Confirm the change of measurement unit by pressing and holding key (A) for 5 seconds until screen (C) appears on the display.

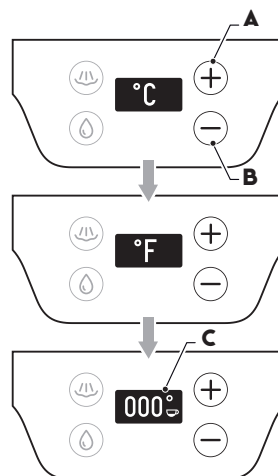

9, CLEANING.



The cleaning must be carried out with the machine off and cold and with the main switch off in "OFF" position and the power cord unplugged, positioning the plug visible.



WARNING: An improper maintenance and cleaning, with the use of untreated water, or damage to the internal parts can cause sudden interruptions of water flow and unexpected jets of liquid or steam, with serious consequences. Be careful when cleaning and using the machine!

9.1, GENERAL CLEANING INFORMATION.

- It is forbidden:
 - use water jets for cleaning the machine;
 - use cleaners containing alcohol, ammonia or scouring pads to clean the machine. USE only specific detergents for cleaning coffee machines or tableware.
 - Chemical cleaners used for cleaning of the machine and / or system should be used with care not to damage the components and the environment (degradability of more than 90%).
 - Clean all the parts and components of the machine.
 - Regularly clean the grinder and check the wear of the grinders.

9.2.

DAILY CLEANING.

CLEANING LANCES

- Thoroughly clean the nozzle (1) at the end of the day (and immediately after every use as described in "water supply" and "steam dispensing") in order to prevent the formation of bacteria or deposits that may block the holes in the speaker and prevent from that drinks of different nature previously heated can alter the flavor of the drinks in heating.

CLEANING DISPENSING UNIT

- Clean shower head (2), sub-cup seal (3), and guide holder in the dispensing unit (4) with a cloth / sponge and cleaning brush.
- Rinse filters and filter holder in hot water with the addition of specific detergent, to dissolve the fatty deposits of coffee.

CLEANING TRAY AND GRILL FOR CUPS

- When the red float (6) comes out of the grid (5), it indicates that the liquid level inside the bowl has reached the maximum level.
- Remove the grille (5) for supporting the cups, pull out the tray (7) for collecting the water discharge and arrange for its cleaning with running water.

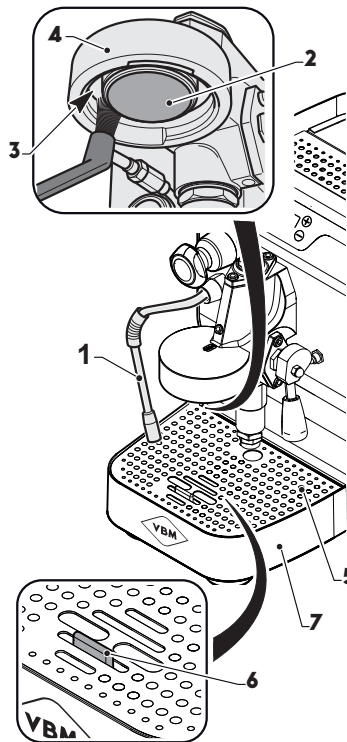

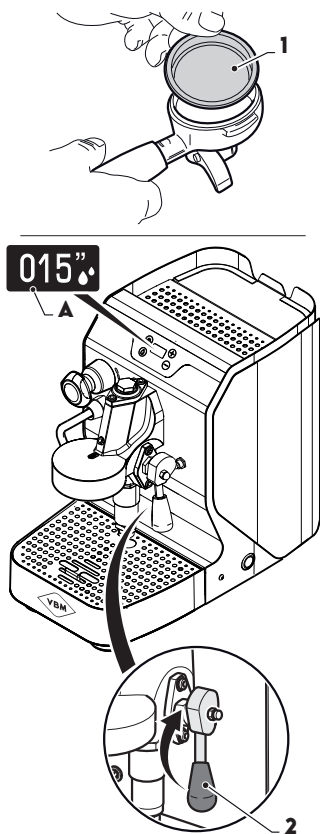

AT THE END OF EACH SESSION OF USE

- Remove the filter from the filter holder and mount the blind filter (1) provided.
- Pour into the blind filter (1) special detergent for coffee machines (for quantities see manufacturer's instructions).
- Start the machine as described in the relevant paragraphs.
- Fit the filter holder with the blind filter on the group.
- Lift the lever (2) and keep it raised for 15 seconds then lower it, the dispensing time is indicated on the display (A); perform this fake dispensing operation 4 times.
- Remove the filter holder from the machine and empty the product.
- Replace the filter holder with the blind filter in the machine and repeat for 4 times the false dispense as described above.
- Remove the filter holder from the machine and remove the blind filter.
- Lift the lever (2) and make a water supply from the group, cleaning the shower head with the brush supplied.



ATTENTION: During the water supply and cleaning the shower head, be very careful, danger of scalding.

CLEANING THE BODY

- Use a damp, non-abrasive cloth on all surfaces. Do not use products that contain alcohol or ammonia that could damage components of the machine.

9.3.

CONTROLS AND REPLACEMENTS.

REPLACING SHOWER HEAD

At least every month you need to replace the shower head (1) for the replacement act as follows:

- Use a screwdriver to pry the shower head (1) and remove it from the group (2) with the gasket.
- Replace the shower head (1) and the gasket (3).
- Replace the seal on the shower, making sure that the notch "A" seal is positioned upward.
- Place the shower head on the holder.
- Fit the filter holder (3) on the group (2) first on the left flap switching it to the end, then on the right flap.
- Fit the filter holder into the machine, as if making coffee and bring it to switch to lock in place the hand shower with the gasket.

CONTROL OF WATER FILTER

Once a month, check the status of the water filter (1) located within the tank; if dirty, replace it.

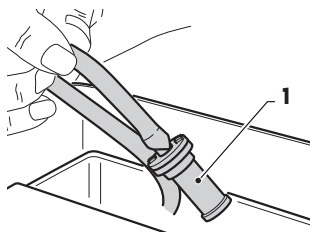
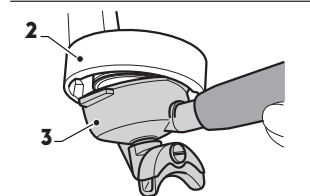
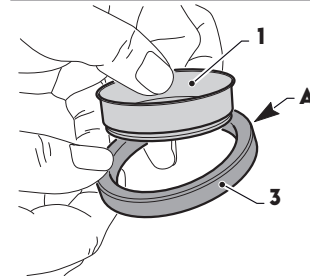
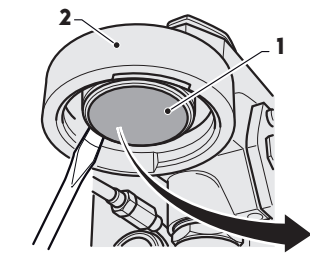



10.

GUIDE TO THE SOLUTION OF SOME PROBLEMS.

In case of malfunction, turn off the machine immediately, and remove the plug from the outlet. Call the Authorized Service Center.

ENG

	Causes	Solutions
The coffee is delivered from the edges of the filter holder.	In the headquarters of the holder there is dirt that prevent the escape of coffee from the spout.	Clean.
	The group seal is consumed.	Replace.
	The shower heads are clogged.	Clean or replace.
The coffee is too cold.	The machine is not ready.	Wait until the temperature indicated on the display is reached.



	Causes	Solutions
The coffee brewing process does not occur or occurs too slowly.	No water in the tank.	Check that the water level in the tank is correct and in case fill with fresh natural water.
	Tube incorrectly positioned.	Place the tube in the correct way.
	Delivery hole of filter holder clogged.	Clean the filter holder with specific detergent and with the help of a toothpick.
The coffee brewing process does not occur or occurs too slowly.	Ground coffee too fine.	Open the grinding to obtain a powder of coffee less fine.
The machine does not produce steam.	Steam switch in position "OFF".	Place the steam switch to "ON".
	No water in the tank.	Check that the water level in the tank is correct and in case fill with fresh natural water.
	Holes in the spout of the steam nozzle clogged.	Clean, with a pin, any deposits formed in the hole of the spout.
	It is possible that the delivery ducts are clogged with limescale.	Call the technician to perform the descaling.



	Causes	Solutions
The machine does not dispense hot water.	Hot water switch in position "OFF".	Set the switch to "ON".
	No water in the tank.	Check that the water level in the tank is correct and in case fill with fresh natural water.
	It is possible that the delivery ducts are clogged with limescale.	Call the technician to perform the descaling.





11, DISPOSAL.

- Putting the machine into disuse must be done by authorized personnel. The pressure of the hydraulic system must be lowered completely, the power cord must be disconnected and substances potentially harmful to the environment must be disposed of legally and properly.
- Store the machine out of the reach of children or unsuitable people.
- **For dismantling as refuse, deliver the car to an authorized plant for the recycling of electrical and electronic equipment (*). This is to prevent any damage to the environment or to humans. For more information about recycling contact the offices of the municipality itself, the service for the disposal of household waste or the retailer.**
- **Do not release to the environment.**

ENG

(*)



Label on the machine as identification of the WEEE directive / WEEE (2012/19 / EC) on Waste Electrical and Electronic Equipment, destined for the European market.

12, ELECTRICAL SCHEME.

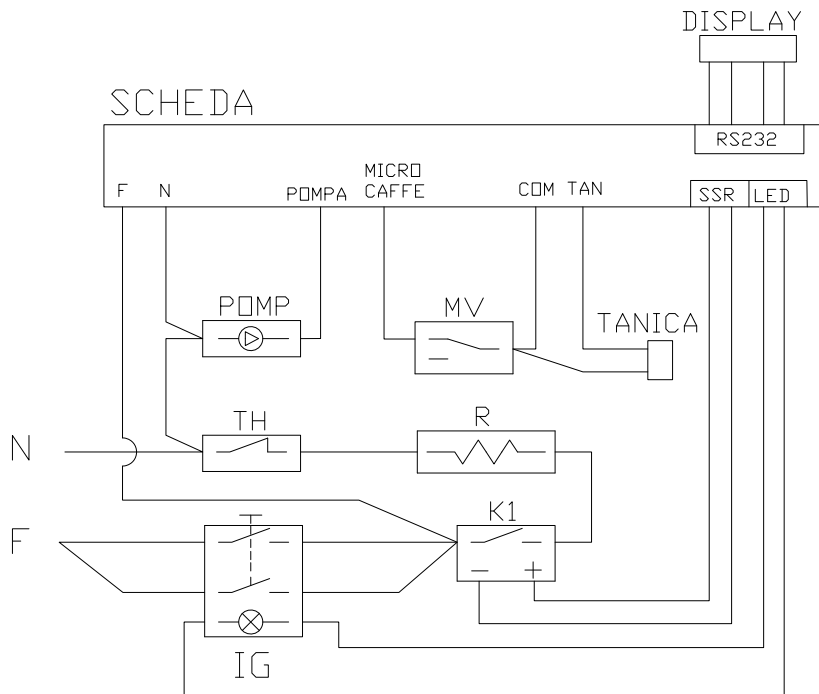



VBIEMME SRL

via Charles Gounod, 25/27 -

20092 Cinisello Balsamo, Milan, Italy

T. (+39) 02 660 16691 · F. (+39) 02 660 16636

info@vbmespresso.com · www.vbmespresso.com